



HATCH THROUGH BOX / PASSBOX



Medi Smart Delivering innovative
and reliable **Medical Engineering**,
tailored for the GCC healthcare sector.



GENERAL SPECIFICATION

Electro-magnetic Interlock Smart Pass-Through Cabinet

Pass Through Cabinets are designed to be mounted in the wall of the cleanroom. These units enable finished drug solutions, parts, tools and other work items to be passed to the cleanroom or pharmacy preparation room. It acts as an air lock device preventing ambient air from entering, or clean air from exiting the cleanroom. The electric interlock prevents both doors being open at the same time thus preventing airborne contaminants from entering the room or pressure loss within the cleanroom

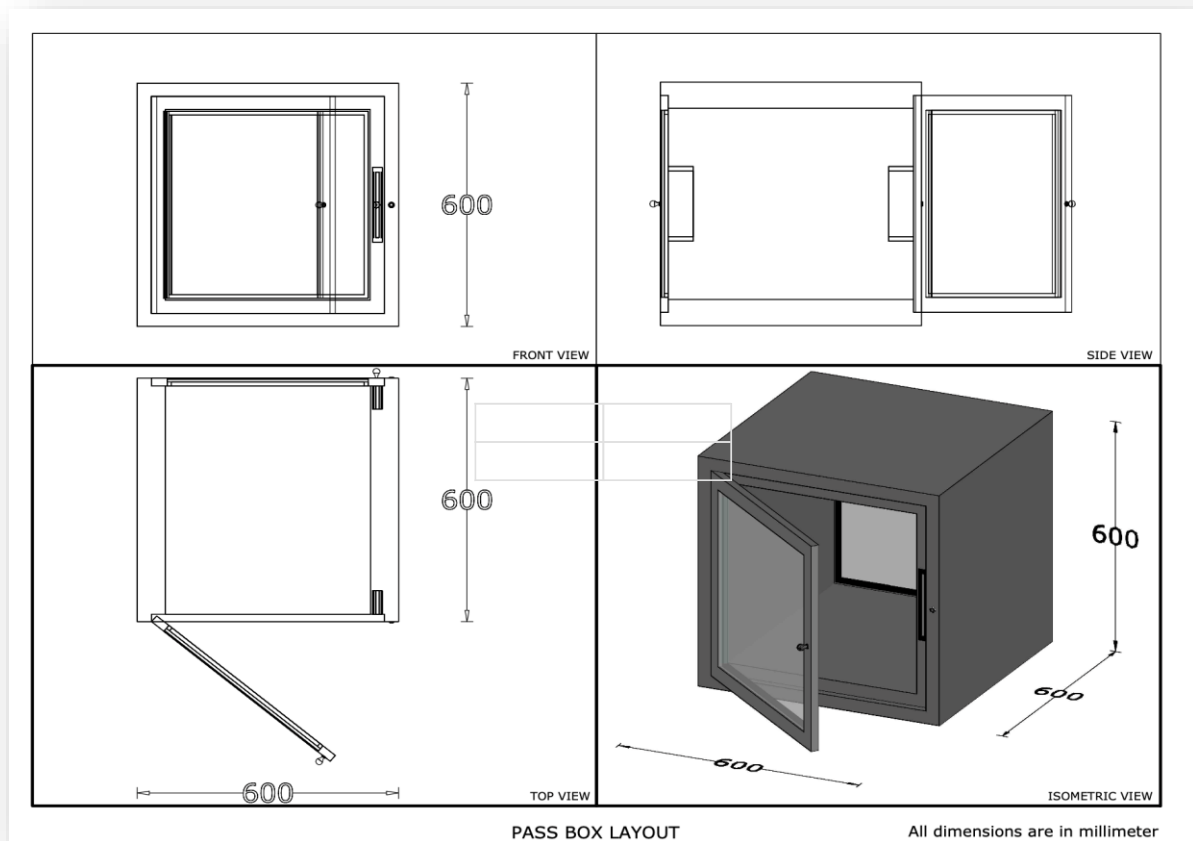

Standard Size

Parameter	Specification
External Dimensions (W x D x H)	600 x 600 x 600 mm
Internal Dimensions (W x D x H)	400 x 520 x 480 mm
Material	Stainless Steel 304 Grade
Lock Type	Electronic Interlock
Windows	Clear Glass Doors

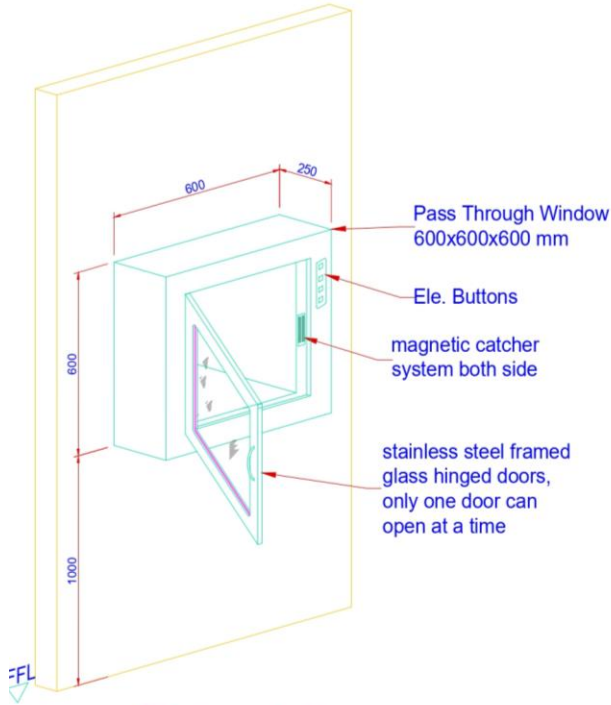

B Isometric View
CF Pass Through - Electrical

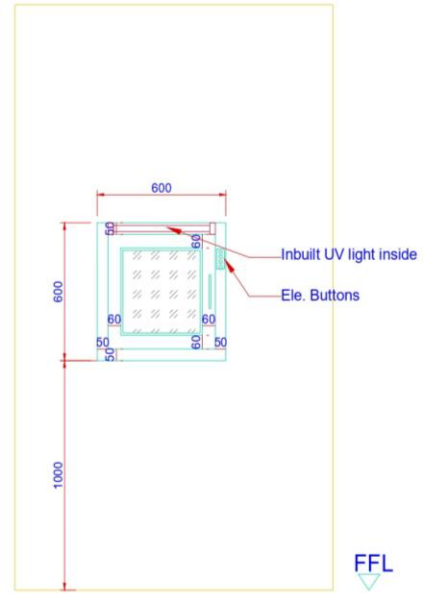

C Elevation
CF Pass Through - Electrical

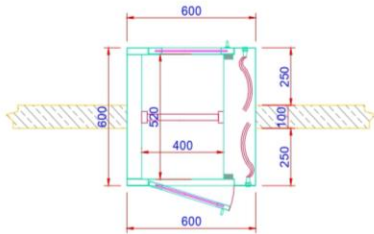

A Plan View
CF Pass Through - Electrical

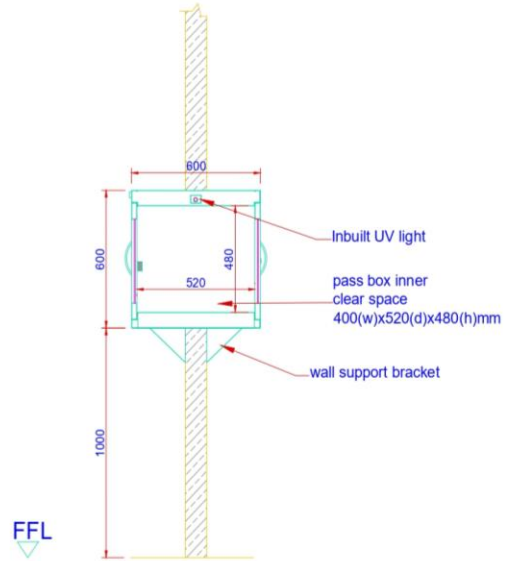

D Section
CF Pass Through - Electrical

Manufacture
MediSmart



Medismart – Advancing healthcare with trusted, high-quality **Medical Engineering** across the GCC.



- Phone: +971 42 500 178
- Mobile: +971 55 585 2360
- Email: info@medismartglobal.com
- www.medismartglobal.com
- P.O. Box: 231673, Dubai